

Stage Fogger DMX

Operator's Manual

Table of Contents

Introduction	3
Microprocessor Control	3
Water Base Fog Technology	3
Warning	3
Important Safety Instructions:	3
Safety Precautions	3
Technical Specifications	4
Technical Drawings	4
Operating Procedure	5
Remote Handset Operation	5
Remote Handset LED Indicator.....	5
Remote and External Control Features	5
DMX Operation	6
Maintenance	6
Exterior:.....	6
Heat Exchanger:	6
Recommended Fluids	6
Warranty	7
Contact Information	7

Note: Please read entire manual before operating the Stage Fogger DMX

Introduction

The Stage Fogger DMX is a Microprocessor Controlled, Water Based Fog Generating System.

Microprocessor Control

The Stage Fogger DMX features microprocessor control. From temperature regulation to taper back flow control, all of the functions are monitored and processed by the on-board processor.

Water Base Fog Technology

Water Base Fog technology is achieved by pumping a glycol/water mixture through a heat exchanger. This will vaporize the fluid as it passes through the hot unit. The vaporization of the fluid forces the hot mixture through the output nozzle. When mixed with ambient air, it forms an opaque aerosol (fog). The fog is made up of tiny droplets that form around small particles in the air. The suspended droplets refract the light, allowing the fog to take on the color of the light illuminating it.



Warning

Important Safety Instructions:

1. Do not touch, place hands or expose skin within 20" (50 cm) of the discharge nozzle.
2. Do not remove the outer case.
3. Persons suffering from asthma or allergenic sensitivity may experience irritation, discomfort or allergic symptoms when exposed to fog effects.
4. Ensure that this unit is grounded at all times. Failure to do so may result in serious injury.
5. Use Ultratec Special Effects fluid **ONLY**.

Safety Precautions

1. Ensure that any operation of the machine is supervised by suitably trained and authorized personnel.
2. Do not modify the machine or use a machine which has been damaged in any way.
3. Allow sufficient air circulation around the machine at all times.
4. Protect the machine from direct weather effects and wet locations.
5. Only use fluids manufactured by Ultratec Special Effects.
6. Do not continue to produce fog when visibility is reduced to 20" (50cm) or below.
7. Avoid directing fog output continuously at people, structures or objects within close proximity of the discharge nozzle.
8. Ensure that adequate exhausting arrangements are available in the event of an emergency.
9. Do not place hands or exposed skin within the first 20" (50 cm) of the discharge nozzle at any time during fog production.
10. Fog effects can trigger smoke alarms and detectors. Please take suitable precautions to prevent false alarms.

Technical Specifications

Model:	Stage Fogger DMX
Part Number:	CLF 4500 - 120 volt CLF 4405 - 220-240 volt
Length:	25.5in 63.5cm
Width:	10.375in 26.3cm
Height:	10.75in 27.3cm
Net Weight:	30lbs 13.6kg
Power Rating:	120 Volt A.C. 50/60 Hz. 13 Amps. 240 Volt A.C. 50/60 Hz. 6.5 Amps.
Fluid:	Ultratec Water Base Fog Fluid
Includes:	Full Timer Remote RCT Replacement Kit On-Board DMX

Technical Drawings

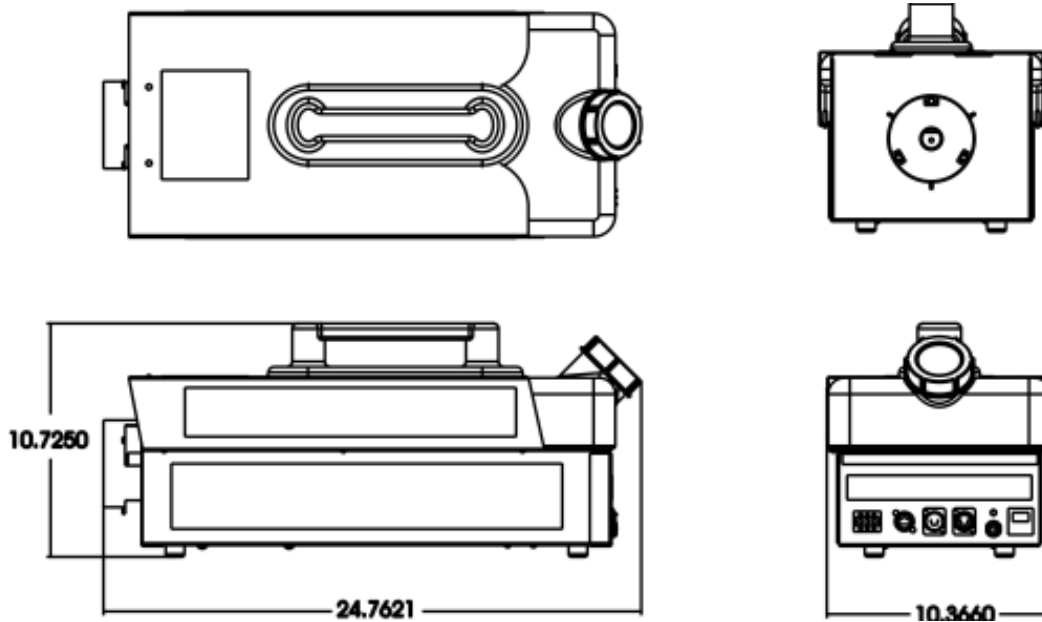

Operating Procedure

1. The Stage Fogger DMX must only be connected to a grounded receptacle capable of sustaining at least 12 Amps. The supply should be 'clean' and free of interference.
2. Open a container of Ultratec Special Effects fog fluid, remove cap and break foil seal (if provided). Remove cap from Stage Fogger DMX fluid reservoir. Fill with fluid, being careful not to overfill reservoir. Replace both caps securely.
3. Connect the remote handset supplied with the machine, to the connector which is located on the rear panel.
4. Turn on the Main Power switch located on the rear panel. The Power switch will illuminate to indicate the presence of power, the handset indicator on the remote handset will also illuminate with a slow flash. If the handset indicator of the remote handset does not illuminate, ensure the connector is properly inserted.
5. The handset indicator will flash slowly as the machine heats up. The indicator will begin flashing quickly when the fog machine is ready to operate. After approximately 9 minutes the indicator light will be solid when the fog machine has fully heated up for full optimum fog output.
6. It may now be necessary to prime fluid into the system to expel any air that might be present. The Variflow control on the remote handset should be set to Full position. A dry hose can take between 45 - 60 seconds to prime. This is normal because of the inside diameter of the hose. This only needs to be done if the unit was left to run dry.

Industrial Option Only:

To adjust the depth of the hose, simply loosen the nut and slide it up or down the hose and retighten. Be careful not to pinch off the flow of fluid.

Remote Handset Operation

The fog output time is set using the 'Duration' control (0 to Max) and the time between successive fog outputs is set using the 'Interval control (0 to Max). Continual flow can be achieved if 'Interval' setting is at 0.

Remote Handset LED Indicator

The Stage Fogger DMX Remote Handset was designed to indicate the following operation modes.

Slow Flashing Light: Indicates unit is not ready to operate but still in heating mode, fog is not available at this point.

Quick Flashing Light: Indicates unit is ready to operate but still in heating mode, some fog is available at this point.

Solid Light: Indicates that the unit is ready to fog at full output.

No Light: indicates problem; a loss of power or remote is not connected. If these fail to correct the problem, contact your local Ultratec Special Effects dealer.

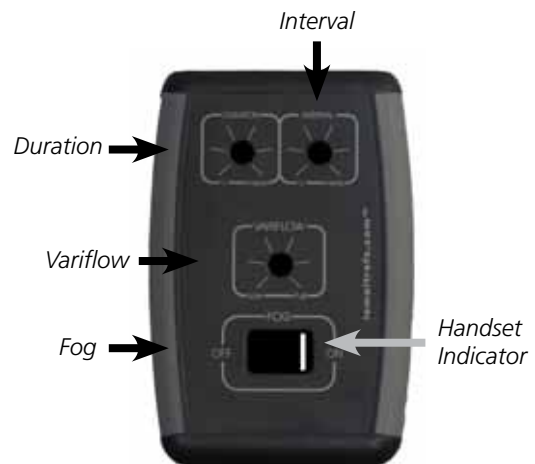

Remote and External Control Features

External Remote Connector

The standard Remote Handset cable may be extended from the machine, and operated effectively away from the Stage Fogger DMX. The maximum recommended cable length is 200 Feet.

DMX Operation

The Stage Fogger DMX comes equipped with onboard DMX Control as a standard feature

1. Plug in the 5 pin DMX cable into the DMX IN connector located on the rear of the Stage Fogger DMX. A terminator may be required if the DMX OUT is not used.
2. Select the DMX address assigned to the Stage Fogger DMX by using the DMX ADDRESS thumbwheel selector located on the rear of the Stage Fogger DMX. If a valid DMX signal is available then the Stage Fogger DMX ignores the settings on the standard remote.
3. Fog output is varied by the DMX signal. 0% is off and 1% - 100% is fog intensity.
4. 15 Amp chassis fuse on the back of the machine.

Maintenance

Exterior:

The casing of the Stage Fogger DMX is steel with a powder paint coating. To clean, simply wash with mild soap and warm water.

Heat Exchanger:

The use of high quality Ultratec Special Effects fluid should result in a long heat exchanger life. (See warranty policy later in this manual.)

Note: Cleaning/Rapid Change procedure can be found on the Stage Fogger DMX product page on www.ultratecfx.com

Recommended Fluids

Director's Choice Fog Fluid: The choice of professionals. Director's Choice creates a cloud of fog with a medium hang time while remaining clean, white, dry, and odorless.

Pro Beam Long Lasting Fog Fluid: With a hang time 2-3x greater than the Director's Choice Fog Fluid, the Pro Beam solution produces a slightly less white fog while remaining clean, dry, and odorless.

Quick Dissipating Fog Fluid: This fast dissipating fluid is great for applications or effects that require quick dissipation of fog. It produces excellent steam effects that resemble nitrogen bursts and it also keeps low-lying fog from rising too quickly when it is used with the LSG or LSX.

Extra Quick Dissipating Fog Fluid: Dissipates 2x the rate of Quick Dissipating Fog Fluid while maintaining similar characteristics.

Molecular Fog Fluid: A faster dissipation versus the Director's Choice Fog Fluid. This thick, clean, white fog is an optimal solution for a dense low-lying fog effect when chilled with the LSG or LSX machines.

Maxi Fog Fluid: The perfect balance between price and performance. Maxi Fog is the ideal solution for those who require high volume without compromise.

EZ Kleen Preventative Maintenance Fluid: Using EZ Kleen preventative maintenance fluid on a regular basis ensures longer life for the heat exchanger in Ultratec fog machines by reducing blockage.

NOTE: All of our fog fluids are water based. Damage will occur if Haze Fluid is used in the Stage Fogger DMX.

Warranty

Warranty:	All warranty is for one year parts and labour unless specified or manufacturer defect only. Abuse or Poor Maintenance will not be covered under warranty. Ultratec Special Effects Fluids must always be used. Use of any non Ultratec Special Effects Fluids will void all warranties. Accept no substitutions as there are no exceptions to this rule. Proof of Purchase or Proof of Sale must always accompany any warranty returns. An RA (return authorization) number must be noted on the outside of the box being returned to our facilities. Any packages without a clearly marked RA number will not be accepted by our receiving department. Freight on warranty items are freight prepaid to our facility and we will prepay freight back to your facility after repair by the most economical means available. Should you require the item express-returned, then you are responsible for any difference in freight cost.
Return Policy:	Return of any product must be done within 30 days of purchase. The package must be returned freight prepaid and the RA number clearly marked on the outside of the box. Minimum restocking fee is 25%. Once our facility has received the product a technical assessment will be completed to determine if an additional restocking fee needs to be issued. Only credits are issued to the dealers account. Any product not returned within 30 days is considered purchased.
Warning:	Ultratec Special Effects Inc. considers all of it's product to be safe for use in the application it was intended. Ultratec Special Effects takes no responsibility for misuse or incorrect use. Always refer to the Product Manual for proper use.

Contact Information

Head Office

Ultratec Special Effects Inc.
1960 Blue Heron Drive
London, Ontario N6H 5L9

Direct: 519-659-7972
Toll Free: 866-534-5557
Fax: 519-659-7713

Canadian Shipping Address

(For All Canadian Repairs)
Ultratec Special Effects Inc.
1960 Blue Heron Drive
London, Ontario N6H 5L9

Please remember to include the **RA Number on all items being shipped for repairs.**

To get an RA Number, visit www.ultratecfx.com and click on the "Service" tab and then click on "Master Service Tracker or contact service at 519-951-3357 / 866.534.5557

USA Shipping Address

(For All USA Repairs)
Ultratec Special Effects Inc.
640 Gadson St.
Groveland, Florida 34736